

BRANCO JUSTIC and PETER PHILLIPS

NIGHT-VISION SCOPES WERE DEVELOPED as military surveillance devices to permit viewing enemy activities and aiming weapons at night without revealing the observer's presence. The sensitivities of their principal components, image tubes, have been improved with fiber-optic lenses, more gain stages and better photocathodes. In addition, miniature, solid-state, extra high-voltage power supplies have reduced their size, weight, and power needs.

Two night-vision scopes are described in this article. One is passive, meaning that it will work in faint natural light, and the other is active, meaning that it requires supplemental infrared illumination. They include surplus first-generation imaging tubes. Although, they have been superseded by more advanced devices, they will, nevertheless, provide adequate sensitivity for most hobbyists and science experimenters.

The active scope *will* permit police to observe suspected criminal activity at night and citizens to monitor their homes or property without being detected. The scope will also permit hunting, nature study, marine navigation, and many other slight time applications. The active scope is suitable for some of these activities, but the scene must be illuminated by an infrared source. Neither will disturb the eyes' adaptation to darkness.

The first night vision scopes were designed for use by forward observers, snipers, aviators, and tank crews. Some that were made as monoscopes to mount on rifles looked like the devices shown in Fig. 1; others were made as binoculars. The most sensitive passive units are called starlight scopes. Night-vision goggles are lightweight binoculars for helicopter crews that mount on their helmets.

Active night-vision scopes, such as the one shown in Fig. 2, depend on infrared illumination from sources such as lasers for aiming artillery guided mis-



View a scene in near total darkness with a passive night-vision scope? or illuminate it with infrared for an active scope

siles, and "smart" bombs. Night-vision systems were considered military secrets for many years. After they were declassified, they could be sold as military surplus and commercial versions based on the technology were offered for police surveillance and as nighttime marine navigational aids at prices that often exceed \$2000.

Both of the night-vision scopes described in this article are based on military surplus equipment that includes both an image tube and optics. The parts for the active unit cost \$90, and parts for the active unit cost 6220.

Night-vision scopes

Figure 3 illustrates a typical night-vision scope. The objec-

tive lens, positioned at the cathode end of the tube, focuses the image on the photocathode. It is selected for its intended application—long-distance or short-range viewing. The eyepiece at the anode is for viewing the enhanced image. If it is a simple lens that magnifies the image on the screen. It can be removed and replaced by a television camera, camcorder, or film camera for transmitting or recording the image.

The image tubes are the hearts of the night-vision scopes. Before you start building one (or both), you might want to learn more about how they work. See the sidebar entitled "Image Converter and Intensifier Tubes."

The only electronics needed

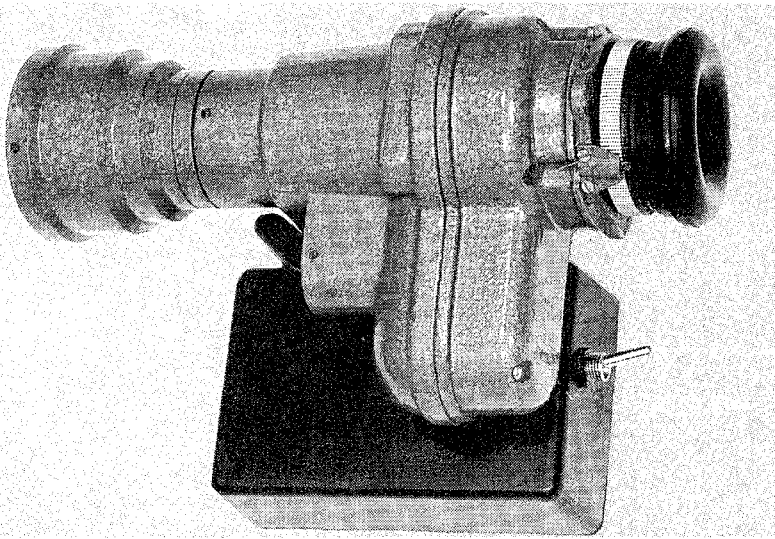

FIG. 1—A PASSIVE NIGHT-VISION MONOSCOPE made from half of a Russian night-vision binocular with an image intensifier tube and all optics.

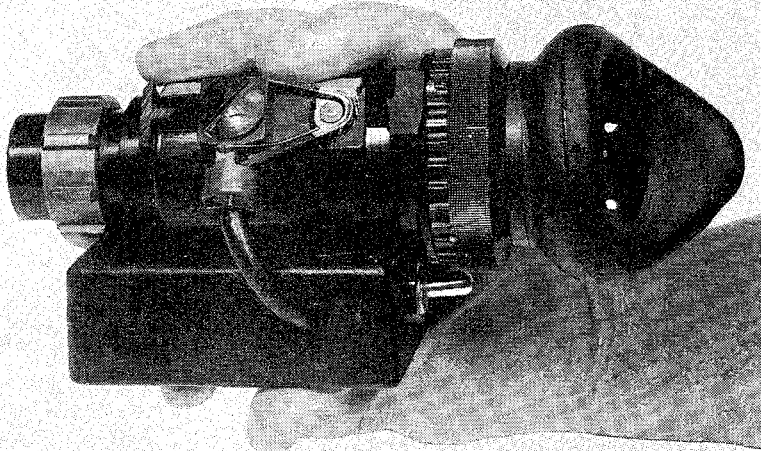

FIG. 2—THIS ACTIVE NIGHT-VISION SCOPE requires an infrared illumination source but it works from the same power supply as the scope in Fig. 1.

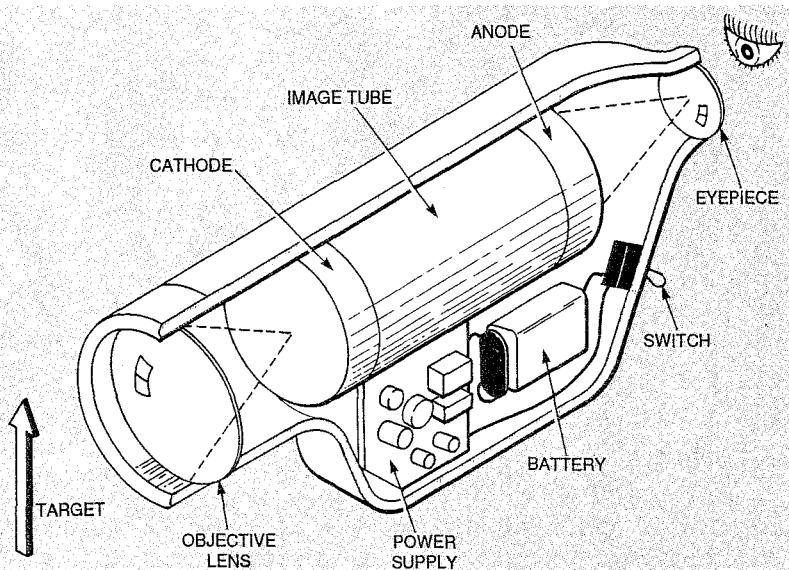

FIG. 3—ALL NIGHT-VISION SCOPES have objective and eyepiece lenses, an image tube, a high-voltage power supply, and a battery.

in both projects described in this article is a high-voltage power supply capable of providing a typical working voltage of 13.5 kilovolts. This efficient and compact regulated supply operates satisfactorily from a 9-volt, alkaline battery. The current drain of both tubes described here is small, so that their power consumption is low.

The compact power supply is built into a small plastic project case that is fastened directly to the surplus night-vision scope that contains the imaging tube. The Russian-made monocular viewer shown in Fig. 1 is actually one half of a binocular. It is complete with an objective lens and an eyepiece. This assembly includes a first-generation, single-stage *image intensifier tube*.

The active night-vision scope shown in Fig. 2 contains a single-stage *image converter tube*. Instructions on how to make several different low-cost infrared illumination sources are described in this article.

Active military night-vision weapons aiming systems typically include an infrared-emitting laser. It pinpoints the target for a heat-seeking weapon or for aiming other kinds of guns or missiles while also acting as a non-visible searchlight for the observer (bombardier or gunner) with an active scope. Various systems have been built for use on land, in the air, or on the sea at night.

Infrared-sensing missiles and "smart" bombs actually "home" on the IR-illuminated target which has been identified by the observer who directs the laser beam and watches it with the active scope. Needless to say, aiming and firing must be fast because enemy gunners with active scopes can also see the laser illumination and take evasive action or retaliate.

Power supply design

Figure 4 is the schematic for a high-voltage power supply that will power both night-vision scopes described here. It produces about 13.5 kilovolts from a 9-volt battery. The tubes draw about 20 milliamperes so about

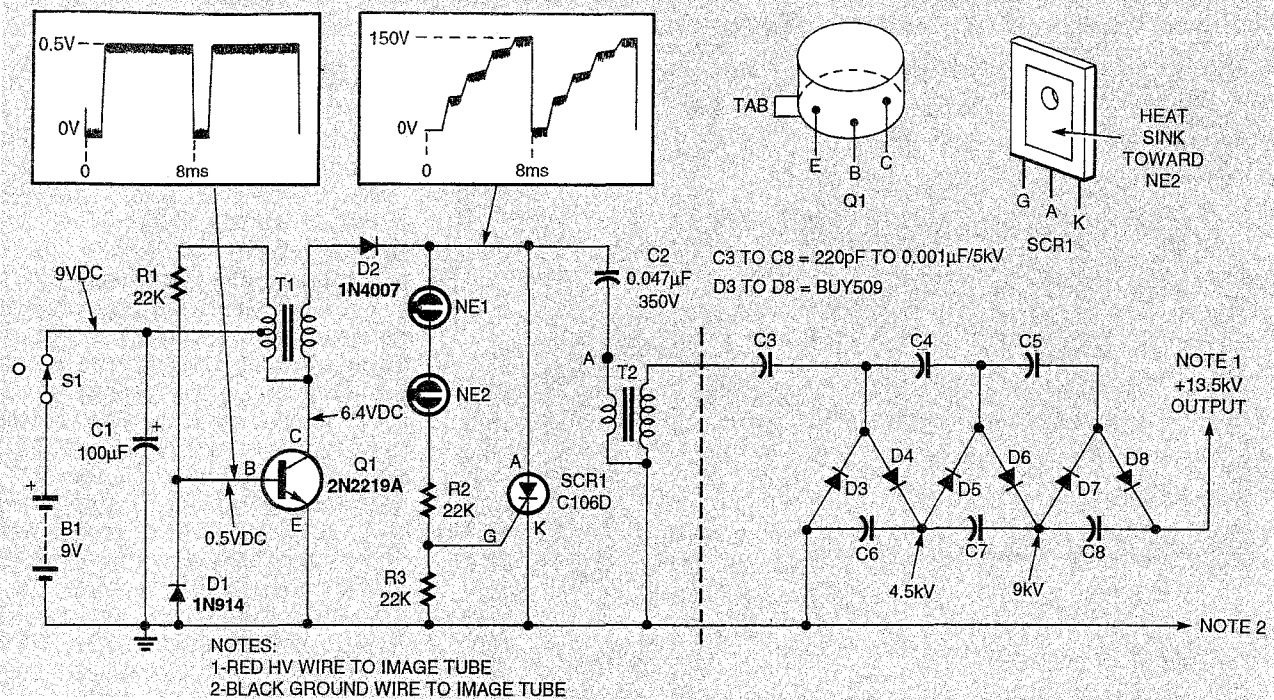

FIG. 4—THIS HIGH-VOLTAGE POWER SUPPLY has an inverter around Q1 that supplies 150-volt pulses to the converter of SCR1 and C2. The output of T2 is a 4.5 kilovolt pulse that is multiplied by the voltage-tripler network (right) to produce 13.5 kilovolts.

36 hours of useful life can be obtained from a 9-volt alkaline battery. The output voltage will remain essentially constant for battery voltages of 6 to 12 volts.

The power supply has three sections: the inverter, the converter, and the voltage multiplier. The inverter section, a ringing-choke oscillator, consists of transformer T1, resistor R1, diode D1, and transistor Q1. Resistor R1 provides bias current for starting the oscillator, and it also supplies the feedback to maintain oscillation.

Diode D1 protects the base-emitter junction of Q1 when the base voltage swings negative. The oscillator operates at about 120 Hz, set principally by the transformer. The resulting AC voltage at the primary of T1 is stepped up by the secondary turns. The secondary voltage, which is rectified by diode D2, charges C2 through the primary (low-resistance) winding of transformer T2.

When the voltage across C2 exceeds the breakdown voltage of the two series-connected neon lamps NE1 and NE2 (about 150 volts) the lamps turn on. This conduction triggers SCR1, and C2 is quickly discharged through SCR1 and the

LIGHT UNITS

The standard (SI) unit of light intensity is the lux, and a typical recommended minimum illumination level for a video camera is around 50 lux. However, some video cameras will work with light levels as low as 1 lux. With this frame of reference, you can get a better idea about how sensitive night-vision systems are.

The recommended light level for the safe operation of these tubes is from 50 millilux down to 500 micro-lux (0.0005 lux)—very low light levels. Table 1 lists familiar light levels and their light intensity in lux units. By contrast, a typical first-generation image intensifier tube will not be damaged if the illumination level is as high as 100 millilux (one tenth of a lux), but tube life will be reduced if it is exposed for long periods to that light level.

Sensitivity is the most important specification for a night-vision scope. An average scope has a sensitivity of 10 millilux (mlx), a value that makes it effective in night light-

primary winding of T2. When C2 is discharged, the lamps extinguish, SCR1 turns off, and the charge cycle starts again.

During the discharge cycle of C2, a pulse with a peak-to-peak voltage of 4.5 kilovolts is produced at the secondary of trigger transformer T2. This pulse

**TABLE 1
RELATIVE VALUES OF
NATURAL LIGHT SOURCES**

Source	Illumination (lux)
Direct sunlight	100,000
Bright sunlight	10,000
Overcast day	1,000
Very dull day	100
Twilight	10
Deep twilight	1
Full moon	0.1
Quarter moon	0.01
Starlight	0.001
Overcast starlight	0.0001

ing from a quarter moon. By contrast, a very sensitive night-vision scope can operate at 1 mlx, which corresponds to starlight conditions. For this reason, very sensitive scopes are called "starlight" scopes.

is applied to the three-stage Cockcroft-Walton or Greinacher voltage-multiplier circuit consisting of diodes D3 to D8 and capacitors C3 to C8.

The multiplier triples the 4.5-kilovolt input to provide the 13.5-kilovolt output with very low current. The capacitors and

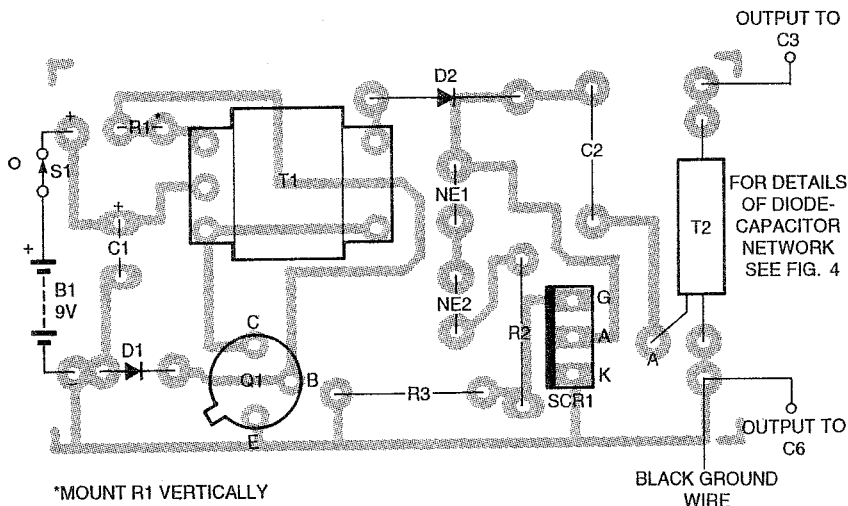

FIG 5—PARTS PLACEMENT DIAGRAM for the high-voltage power supply. Refer to Fig. 4 for the layout of the voltage-tripler network that is connected to its output.

PARTS LIST

Resistors are ¼-watt, 10%

R1, R2, R3—22 kilohms

Capacitors

C1—100 µF, 25 volts, aluminum electrolytic

C2—0.47µF, 350 volts, polyester

C3, C4, C5, C6, C7, C8—220 pF, 5 kV breakdown, ceramic

Semiconductors

D1—1N914 silicon signal diode

D2—1N4007, 1000V, 1A silicon diode (DO-41 case), Motorola or equiv.

BY509—silicon diode, 10 kV, 3 mA, Philips or equiv. (rating must be greater than 6 kV, 2 mA)

2N2219A—NPN transistor, Motorola or equiv.

MCR106-6 (C106D)—SCR, 400 V, 4 A in a T-126 package, Motorola or equiv.

Other components

NE1, NE2—neon tubes, miniature
T1—transformer, inverter, 3 kilohm CT, iron core, audio, miniature PC mount

T2—transformer, trigger type, 250 V primary, 6 kV secondary

Miscellaneous printed circuit board; passive night-vision monoscope with imaging tube and optics (see text); active night-vision scope with converter tube (see text); plastic project box (see text); 9-volt alkaline transistor battery, 9-volt transistor battery clip with wires; miniature toggle

switch, PCB mounted; plastic sleeving; RTV silicone potting compound; tinned copper wire, 22 AWG; insulated hookup wire, 22 AWG, solder.

Note: The following items are available from Oatley Electronics, P.O. Box 89, Oatley, Sydney, NSW, Australia 2223: Phone 011 61 2 579 4985 (Time zones USA—East 7 PM to 2 AM, Central 6 PM to 1 AM, Mountain 5 PM to 12 AM, Pacific 4 PM to 11 PM), Fax 011 61 2 570 7910. Mastercard and Visa accepted with telephone or fax orders, international bank drafts and money orders accepted by mail. Customers please include phone and/or fax number.

• Complete kit of passive night-vision scope and parts for the HV power supply—\$220.00

• Complete kit of active night-vision scope and parts for HV power supply—\$90.00

• Kit of parts for HV power supply only—\$24.00

• Kit of non-standard parts (T1, T2, NE1, NE2, and C2)—\$8.00

Include \$15.00 for shipping and handling, \$6.00 for air mail from Australia.

put is nearly constant for DC input voltage from 6 to 12 volts, the operating frequency of the inverter/oscillator increases with the DC input voltage. The waveforms and frequencies shown on Fig. 4 were obtained with a 9-volt input.

Building the power supply

All the electronic components of the power supply except the capacitors and diodes in the voltage tripler are mounted on a 1¹⁵/₁₆ × 1¹/₅-inch printed-circuit board that will fit with a 9-volt rectangular battery inside a 2 × 3³/₄ × 1-inch plastic project case. A foil pattern has been provided here for those who want to make their own circuit boards.

Refer to parts placement diagram Fig. 5. Insert SCR1 so that its metal heatsink faces neon lamp NE2. When inserting electrolytic capacitor C1 and diodes D1 and D2, observe their polarities. Mount resistor R1 vertically on the circuit board. Solder all components and trim excess lead lengths.

Refer back to the schematic Fig. 4, and wire the leads of capacitors C3 to C8 and diodes D3 to D8 together mechanically to form a rigid unit according to the schematic. Keep all exposed lead lengths about ¼-inch long. Then solder the network together as rapidly as possible to avoid applying damaging excessive heat to the capacitors and diodes. The cathodes of some diodes are identified with a red dot on the cathode lead.

Figure 6 shows the completed power supply with the tripler network to the right of the board. Battery B1 and switch S1, both off-board components, are not shown. Solder one lead from C3 and one lead from C6 in the tripler network to the terminal points on the circuit board, as shown in Fig. 5. (The tripler will be potted in silicone after the system has been tested.)

NOTE: The image converter tube in the active night-vision scope shown in Fig. 2 requires a positive ground. If you build this unit, reverse diodes D3 to D8 to convert the supply from one with a positive to a negative output with respect to ground.

diodes must be rated to withstand at least 4.5 kilovolts. For this reason, the capacitors are all rated at 5 kilovolts, and the diodes are high-voltage units.

The neon lamps regulate the output so that the voltage applied to the primary of T2 is constant at 150 volts, peak. Although the power supply out-

Mechanical assembly.

Drill a hole in the body of the plastic project case for mounting the miniature toggle switch S1. The location of the switch is not critical, but it should not interfere with the other components. In the passive night-vision scope, it was positioned at the end of the case facing the eyepiece.

Drill the hole in the case for mounting it to the passive scope body with a single screw. The hole for this screw, already drilled and tapped in the body of the scope, is located under the coupling bracket. Drill another hole large enough to pass the power cable to the image tube. Its location will depend on the project you build. Mount switch S1 in the sidewall of the case. Fasten the case to the passive viewer with a screw. If you build the active viewer, cement the case to the scope body with epoxy, as shown in Fig. 2.

Cut the supply lead from the scope about 6 inches long, and strip back about 1 inch of the jacket to expose the braid and the insulated central conductor. Twist the braid into a lead and insulate it with a length of plastic tubing. Insert the cable lead into the project box, solder the braid to the ground connection of the circuit board, and solder the inner conductor to the high-voltage terminal of the tripler network, as shown in Fig. 4.

Verify that there are no short circuits in the construction of the tripler and that the leads are spaced by at least 1/4-inch from each other. Wire toggle switch S1 in series with the positive lead from the battery clip. Cut the battery leads from the circuit board so they are long

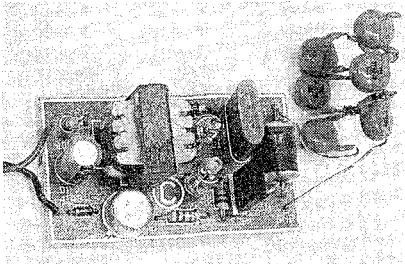

FIG. 6—COMPLETE HIGH-VOLTAGE power supply circuit board with the voltage-tripler, diode-capacitor network shown unpotted at right.

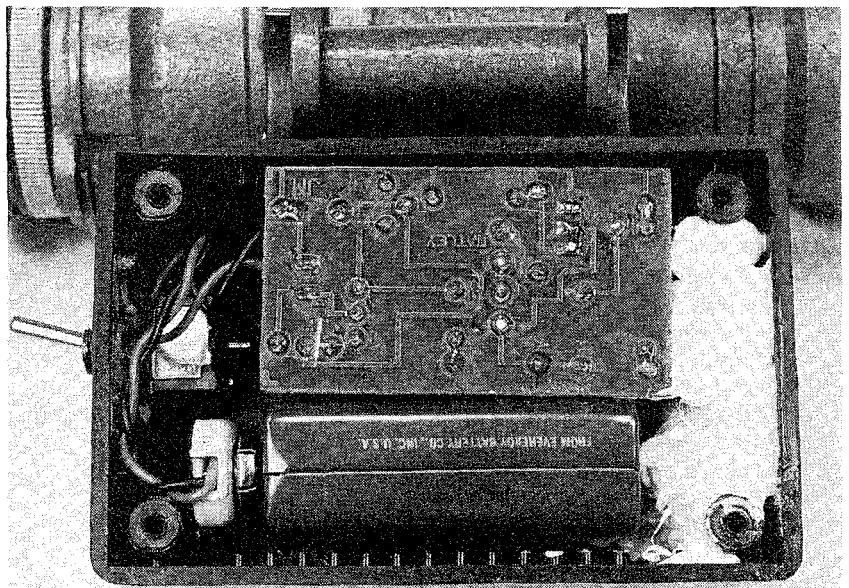
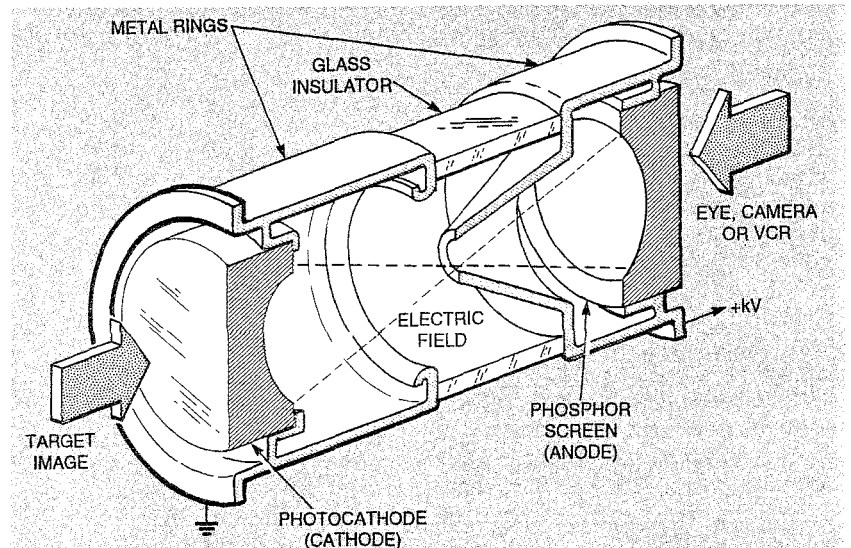

FIG. 7—POWER SUPPLY CIRCUIT, battery, and switch in the project case. The tripler network potted in silicone is shown as the white patch at right.



CUTAWAY VIEW OF SINGLE-STAGE image tube showing the position of its key parts.

enough to permit lifting the circuit board out of the case. Insert the battery and wiring in the case, but leave the tripler network and circuit board outside temporarily.

Test and checkout

After rechecking your work and verifying the polarities and orientation of all components, snap the battery to the battery clip. The current drain on a 9-volt alkaline transistor battery should be about 20 milliamperes in a correct circuit.

WARNING! The power supply described in this article produces an output voltage of

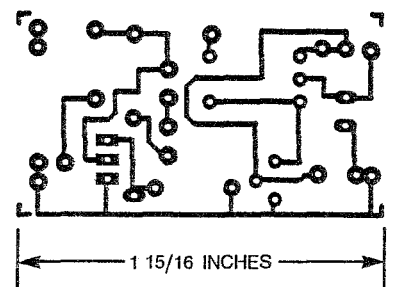

FOIL PATTERN FOR POWER SUPPLY circuit board.

about 13.5 kilovolts, and is capable of giving you a startling electric shock. While not normally life-threatening, it can have a temporarily debilitating effect. Consequently, treat it

with respect and always make sure switch S1 is off and the capacitors are discharged before handling the circuit board.

When you switch on S1, a corona discharge might appear around the tripler network. This is non-destructive, but avoid electrical shock by keeping your hands away from that part of the circuit.

Alternatively, you can test the power supply by placing a wire connected to the circuit's ground bus close to the high-voltage output lead. It should produce an arc as much as 1/4-inch long.

When the switch is off, connect the ground wire directly to the high-voltage output to discharge all the capacitors. Because of the short-duty cycle discharge pulses, the illumination of neon lamps NE1 and NE2 will be visible only in darkness.

If power supplies have been built and installed correctly, the phosphor screen of the image tube should emit a green glow, whether or not light is incident on the cathode. The green glow persists for a about a minute after the power has been switched off, indicating that sufficient voltage still exists between the anode and cathode to form an image.

If, after following the directions closely and checking your workmanship, the scope still doesn't work, check the voltages at the base and collector of transistor Q1 with a digital voltmeter. The values shown on the schematic, Fig. 4, are DC values expected with a 9-volt power supply.

Do not attempt to measure the high-voltage output directly unless you have a suitable high-voltage probe on your meter. The waveforms shown were also obtained with a 9-volt supply. If you don't have an oscilloscope available, measure the AC voltage at the test points shown on Fig. 4.

The reading on most digital voltmeters will be RMS values, but they will give you a valid indication if there is a signal. The AC voltage at the cathode of D2 (to ground) of the prototype measured about 45 volts RMS

IMAGE CONVERTER AND INTENSIFIER TUBES

An image tube is a vacuum tube that converts an image in one part of the electromagnetic spectrum to another part of the spectrum, usually with an increase in intensity. If, for example, you want to convert a near-infrared (IR) image to a visible light image, you would use an *image converter tube*. This is the tube in the active night-vision scope described in this article. However, the scene must be illuminated by an infrared source if the scope is to function.

However, if you just want to intensify a scene in darkness you would use an *image intensifier tube*, the kind included in the passive night-vision scope described here. The figure shows a simplified cutaway view of this kind of tube. While it is also sensitive to near IR, it is still called an image intensifier.

Both tubes have photoemissive input surfaces at their cathode ends that form an electron image of the scene being viewed when a voltage of 4 to 20 kilovolts is applied between the cathode and anode. Photons from the scene or target are focused on the photocathode which triggers an avalanche of electrons. The anode accelerates the cascaded electron emission from the photocathode and focuses them on a phosphor screen to display the image.

Image tubes are now made in many different sizes with different photocathodes, electron focusing techniques, and gain mechanisms. The tubes in the night-vision scopes described here are examples of first (or zero) generation, single-stage converters that are electrostatically focused. More advanced tubes obtain higher gain by cascading two or more converter stages.

For night-vision applications, the earlier generations of image tubes had simple glass lenses and S25 photocathodes that closely match the peak sensitivity of the human eye. These tubes produce a high-definition black and green image. The latest versions now have fiber-optic lenses, gallium-arsenide photocathodes, and gain stages called *microchannel plates*.

In night-vision scopes, the image must be formed on the cathode by an objective lens similar to a camera lens, and the scene is viewed at the anode end with an eyepiece.

It is important to remember that no passive image intensifier tube will work in complete darkness. It must gain enough light from natural background sources to work. These might only be barely perceptible even to the night-adapted human eye. The sources could be faint sky glow on a cloudy night, starlight on a clear night or moonlight.

on a DMM. The AC voltage at the base of Q1 was about 0.45 volt RMS.

When the scope is working properly, switch off the power and wait for the tube to discharge completely. Insert the tripler section carefully inside the case as shown at the right side of Fig. 7. Encapsulate it with neutral-cure, room-temperature vulcanizing (RTV) silicone potting compound to prevent high-voltage corona and discharge, which increases with relative humidity. The compound will also fasten the tripler network inside of the case.

Viewing with the scope

The lens of the surplus Russian passive night-vision scope specified in this article is focused to infinity, making it useful for viewing images more than a few meters away. By loosening a small locking screw, the lens can be adjusted. This will permit viewing objects more than 100 meters away under near starlight illumination.

Imaging tubes will be damaged if they are exposed to bright light for long periods. Don't use either scope in sunlight, or even in well lighted rooms. Always cover both ends of a night-vision scope with suitable lens caps when it is not in use to keep the imaging tube in darkness. The monocular passive scope offered by the source given in the parts list has a rubber lens cap that can be snapped in place. It also has a focusing eyepiece.

Both of the night-vision scopes will detect IR energy, so they can verify the operation of stereo and TV remote controls. In a darkened room, point the emitting face of the control at the scope. A pulsing green light will be seen when any of the remote control's keys are pressed. A TV remote control can also serve as a temporary IR illuminator.

IR light source

A better IR source can be made by covering a flashlight with an IR filter. You can pur-

Continued on page 73

with the component values shown in Fig. 12. The circuit can only lock to input signals within this frequency range.

Figures 13 and 14 are schematics for several practical *frequency multiplier* circuits. The circuit in Fig. 13 serves as a multiply by 100 frequency multiplier/prescaler that can change 1 Hz to 150 Hz input signals into 150 Hz to 15 kHz output signals.

The circuit in Fig. 14 is a simple frequency synthesizer. It is fed with a precise (crystal-derived) 1-kHz input signal, and its output is a whole-number multiple (in the range $\times 1$ to $\times 9$) of this signal. The CD4017B is organized as a programmable divide-by-N counter in this application. A single CD4017B can be replaced by a series of programmable decade counters to form a wide-range (10 Hz to 1 MHz) synthesizer. Ω

NIGHT VISION SCOPES

continued from page 62

chase a suitable IR filter at most retail camera stores, or you can stack four or five layers of completely exposed, developed film negatives between the incandescent lamp and flashlight lens. This film can be obtained as scrap from local photo developing shops. Cut four or five disks from this exposed film to fit inside the plastic or glass lens cap of your flashlight.

A complete kit of parts to build both of the scopes described in this article can be obtained from the source given in the parts list. If you elect to buy a surplus image tube to make a night-vision scope from scratch, purchase or obtain a "fast" camera lens and a magnifying glass for use as an eyepiece. You can then assemble all of these parts in a suitable metal or plastic tube. The power supply described here will power most imaging tubes, regardless of their size or country of origin. Ω

FUNCTION GENERATORS

continued from page 50

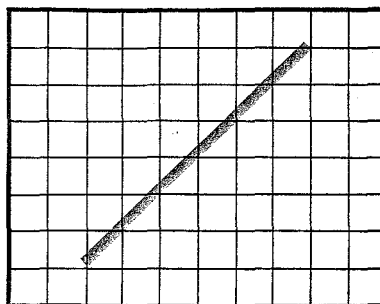

a

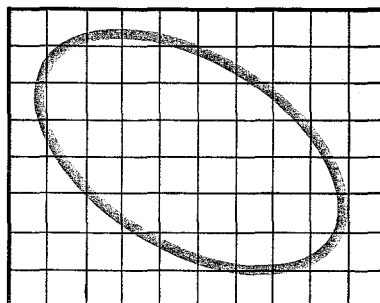

b

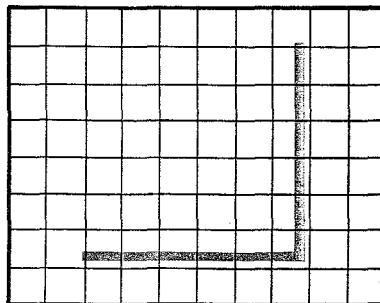

c

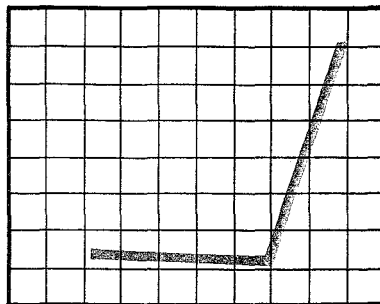

d

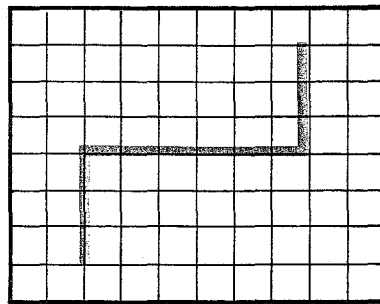

e

Note: A copy of B&K Precision's *Guidebook to Function Generators* will be sent to any reader free of charge by addressing a request in writing to Guidebook, B + K Precision, 6470 West Cortland Street, Chicago, IL 60635.

nature represents the forward voltage drop. The vertical part of the signature represents the forward current, and the horizontal part represents the reverse voltage drop.

In the waveform for the Zener diode in Fig. 9-d, the forward current is a function of the forward voltage. But when the reverse voltage equals the PN junction breakdown voltage, reverse current increases rapidly, producing a vertical line in the lower left quadrant of the screen. This line is the *break-over point* or Zener voltage, and it is established by the knee in the signature.

The signature technique can be applied to test and explain the operation of all electronic components. It is simple to use, it can speed troubleshooting, and it works well on unpowered circuit boards. Even electronic service centers operating under tight budget constraints can afford this method.

It is worth noting that two functionally identical ICs which seem to be operating normally can have different pin signatures because of differences in chip fabrication. You might encounter this when testing functionally identical IC's from different manufacturers. Different signatures do not necessarily indicate a device fault.

With experience in the careful interpretation of signatures, signature analysis can help you to identify defective components quickly—even those with marginal problems. Defective ICs (open-circuited or short-circuited) can be isolated rapidly by persons with little or no experience doing this. Ω

FIG. 9—NORMALIZED CURRENT VS. VOLTAGE SIGNATURES for electronic components: resistor (a), inductor or capacitor (b), silicon signal diode (c), light-emitting diode (d), and Zener diode (e).